

■ DATA SHEET FIRE TRAILER FT40 / FT60 FIRE TRAILER WITH MONITOR.

■ 1. TECHNICAL DATA.

Type	FT40	FT60
Max. water flow rate	40 000 l/min	60 000 l/min
Adjusting range of water flow rate	10 000-40 000 l/min	20 000-60 000 l/min
Max. operating pressure	16 bar	
Horizontal swiveling range	360° (without limitation)	
Vertical swiveling range	+30° / +80°	
Hose connection / water supply	2x 12" Multilug couplings, individual shut-off possible with a shut-off valve	
Drawbar	Height-adjustable with ball head coupling or towing eye	
Working platform	Hydraulic lowering for operation is possible	
Permitted total weight	2500 kg	3500 kg

■ 2. MATERIALS.

Monitor	See separate data sheet Monitor
Pipework	Galvanized steel
Chassis	Galvanized steel



■ 3. EXAMPLE FIGURE / DIMENSIONS.

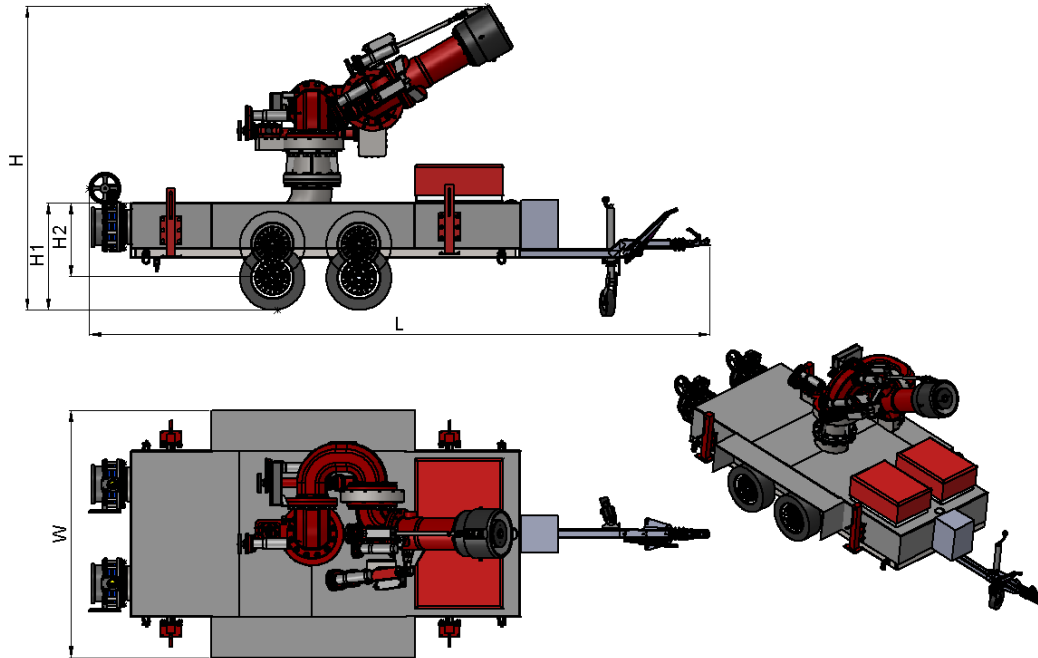

Type	FT40	FT60
Length L	ca. 5000 mm	
Width W	ca. 2000 mm	
Height H ¹	ca. 2500 mm	ca. 2650 mm
Height of platform in driving mode H1	ca. 870 mm	
Height of platform in operating mode H2	ca. 600 mm	

¹⁾ Height in driving mode

■ 4. MANUFACTURER.

FireDos GmbH, Auf der Kaulbahn 6, 61200 Woelfersheim, Germany
 Phone +49 (0) 6036 9796-0, Email: info@firedos.de

We reserve the right to make modifications at any time.